

***HAMPTON***

---

Installation, Operation and  
Maintenance Manual

**Vari Speed S1000  
Instruction Manual**

## TABLE OF CONTENTS

Introduction	4
Unit Features	5
Operating Conditions	6
Specifications	7
Ratings Chart	8
Dimensions	9
Mounting & Installation	10
Unit Functions	13
Schematic Block Diagram	14
Wiring	18
Verification Test	19
Component Location	21
Set-Up Procedures	22
Two-Speed Application	27
Troubleshooting Guide	28
Plug-On Terminal Option	30
Available Options	31

Details and specifications presented in this manual are subject to change without notice.

## INTRODUCTION

The new Vari Speed S1000 is setting new standards in the field of inexpensive DC motor controllers. The smallest member of the family includes features and performance only before thought possible in larger, more expensive units. By utilizing the latest in surface mount component technology and manufacturing processes, this controller is unsurpassed in performance and reliability.

Vari Speed S1000 is a solid state controller that converts single phase AC line power into an adjustable DC power source. The unit has been designed to control permanent magnet (PM), or shunt wound DC motors from 1/20 to 2HP. This NEMA Code K (2 SCR's, 2 diodes, and a freewheeling diode) converter ensures good form factor and smooth, efficient motor operation. Because of the unit's small physical size and convenient mounting arrangement, it can be located in panels with very limited space.

If you have any questions regarding the Vari Speed S1000, please contact your local distributor, or consult the factory by calling toll free 724-861-0150.

## UNIT FEATURES

The following features are standard on all Vari Speed S1000 DC controls:

- Surface mount technology - reduces size, improves performance and reliability.
- Power supply uses control transformer and voltage regulators for optimum performance.
- Full wave bridge rectifier with free-wheeling diode for optimum performance.
- Full or half wave field supply for wound field DC motors.
- Speed controlled by 5k ohm potentiometer, 0-5V or 0-10V input signal.
- AC line switching for ON/OFF with automatic ramp reset.
- RUN/STOP and INHIBIT control via external switches (user supplied).
- Status LED's for CURRENT LIMIT and RUN.
- Plug-In Current Sense Resistor easily changed to provide Armature Feedback for wide horsepower range (optional heatsink required for larger horsepower).
- Independently Adjustable MIN/MAX Speed.
- Adjustable Current (Torque) Limit.
- Adjustable IR Compensation.
- Independently Adjustable linear ACCEL/DECEL.
- 100% factory tested for assured reliability.
- Full two (2) year warranty.

## OPERATING CONDITIONS

AC Line Voltage Variation	Rated Voltage (+/- 10%)
AC Line Frequency	48 to 62 HZ
Ambient Temperature	32° F to 131° F (0° C to 55° C)
Elevation	Up to 3000 Feet (1000 meters) without aerating

NOTE: The Ambient Temperature specification is referring to the environment surrounding the S1000 printed circuit board, not necessarily the room temperature.

## CONTROL SPECIFICATIONS

Service Factor	1.0
Form Factor	1.3 5
Duty	Continuous
Overload Capability	150% for 1 minute
Speed Regulation	2% of Base Speed (for 95% Load Change)
Speed Range	50:1 @ Full Torque
Speed Potentiometer	5k ohm, 1W available accessory
Process Signal Input	0-5VDC or 0-10VDC (See Wiring and Warning on pg. 16)
Adjustments	<b>Minimum Speed</b> (0-50%) of motor base speed) <b>Maximum Speed</b> (50 110% of motor base speed ) <b>IR Compensation</b> (Adjustable from 0 to 25% of rated output.) Current Limit (10-150% of Control Rating) <b>Acceleration</b> (1/2 to 15 Seconds) <b>Deceleration</b> (1/2 to 15 Seconds)

# RATINGS CHART

AC Line Voltage	HP	Kva	DC Armature Voltage**	A Current (Amps)	Field Voltage	Field Current (Amps)	Dual Element Fuse Amps	Current Sense Resistor (ohms)	Part No.
120	1/20	0.75	0-90	1.0	50/100	1	1	0.1	176B1115
	1/8	0.25	0-90	2.4	50/100	1	2.5	0.044	176B1116
	1/4	0.5	0-90	4.0	50/100	1	4	0.027	176B1117
	1/2	1	0-90	6.8	50/100	1	8	0.016	176B1118
	3/4	1.5	0-90	9.6	50/100	1	10	0.011	176B1119
	1	2	0-90	12.2	50/100	1	15	0.009	176B1120
240	1/10	0.75	0-180	1.0	100/200	1	1	0.1	176B1115
	1/4	0.5	0-180	2.0	100/200	1	2	0.044	176B1116
	1/2	1	0-180	3.4	100/200	1	4	0.027	176B1117
	1	2	0-180	6.1	100/200	1	8	0.016	176B1118
	1 1/2	2.5	0-180	8.3	100/200	1	10	0.011	176B1119
	2	4	0-180	10.8	100/200	1	15	0.009	176B1120

Note: If motor horsepower to be used falls between two of the standard Current Sense Resistors, use the higher values of the two (Example: 1/3 HP uses 1/2 HP Current Sense Resistor)

# DIMENSIONS

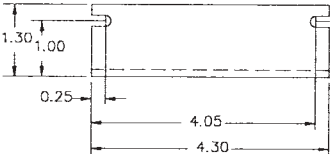
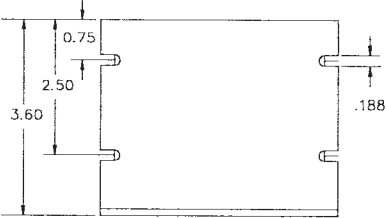

DIMENSIONS IN INCHES



## MOUNTING AND INSTALLATION

This equipment should be installed, adjusted, and serviced by qualified electrical maintenance personnel familiar with the construction and operation of this type of equipment and the hazards involved. It is the responsibility of the equipment manufacturer, or person installing the controller, to take diligent care. Read all warnings and notes before proceeding to install or operate this control.

The Vari Speed S1000 should be mounted in an enclosure appropriate for the application's environment. Failure to do so could cause equipment malfunction or serious personal injury.

When using the higher horsepower units, the optional 176B1122 heatsink is recommended to ensure the proper heat dissipation. The 176B1122 provides 160 square inches. This figure is based on anodized aluminum; the type of metal and its finish will affect the thermal resistance. The area will have to increase accordingly to ensure proper cooling.

NOTE: Recommended minimum mounting clearance on the top and bottom perimeter of 2 inches should be maintained to ensure proper cooling. NOTE: Fast-on (1/4" and 3/16") connectors are required for wiring when optional terminal board is not used.

1. **WARNING: IMPROPER INSTALLATION OF MOTOR AND CONTROLLER MAY CAUSE EQUIPMENT FAILURE, OR SERIOUS PERSONAL INJURY.**

FOLLOW INSTRUCTION MANUAL, LOCAL, STATE, AND NATIONAL SAFETY CODES FOR PROPER INSTALLATION. ALWAYS DISCONNECT POWER TO THE CONTROL BEFORE MAKING ANY WIRING CHANGES, OR BEFORE INSPECTING EQUIPMENT.

2. It is strongly recommended that the “L” bracket or heatsink of the unit is mounted to a grounded surface.
3. The National Electrical Code requires a separate fused disconnect or circuit breaker be installed in the incoming AC power line. See Ratings Chart (page 8) for proper sizing.
4. All components on printed circuit board are at line potential. Extreme caution should be exercised when working on unit. Except where required for set-up, power should always be disconnected from the unit before any work is attempted.
5. Do not apply AC line voltage to any terminals except L1 and L2. Failure to comply will cause permanent damage to the control.
6. All remote connections to the controller should use shielded wire; Speed adjust potentiometers -3 conductor shielded; Run Circuit, Tach Feedback, Tach Follower, and voltmeters connected to Tach Generators -2 conductor shielded. Shields should be grounded at the control only. The other end should be isolated to avoid accidental grounding. Route these conductors separately from motor and power wiring.

Automatic restart of control may occur if line power has been temporarily lost. Caution should be exercised under such circumstances.

Motor overload protection must be provided by the equipment manufacturer or person installing controls per National Electrical Code.

## UNIT FUNCTIONS

### RUN/STOP:

A closed contact between the RUN and V+ will start the control as long as the INHIBIT is not activated. At the time of the START command, the unit will follow the adjustable ACCEL ramp to the Speed Input setting. Opening the contact between RUN and V+ will initiate a STOP command to the unit. The control will follow the setting the adjustable DECEL ramp to zero speed.

### INHIBIT (INH):

The INHIBIT input is the priority logic command, overriding all others. When activated, the INHIBIT will turn the control's armature output off, regardless of a RUN or Speed Command input. As the INHIBIT circuit is activated, any DECEL ramp the control is set for will be cancelled. This allows the control's output and internal logic to reach their OFF-state as fast as possible. The time it takes for the motor to reach a zero speed condition, however, will be dependent on the inertia present on the motor's shaft.

To provide the optimum flexibility for various logic schemes, the INHIBIT may be set for use with Normally Open (NO) or Normally Closed (NC) types of contacts. This allows the S1000 INHIBIT circuit to be activated during either an Open or a Closed contact condition.

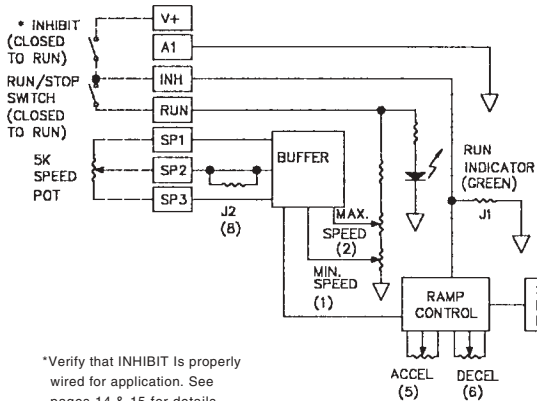

\*Verify that INHIBIT Is properly wired for application. See pages 14 & 15 for details.

NOTES:

1. Factory set at 0 Vdc.
2. Factory set for 90 Vdc for 120V controllers, 180 V dc for 240 V controllers.
3. Factory set for 100% of controller rating.
4. Factory set for zero compensation.
5. Factory set for 1/2 second.
6. Factory set for 1/2 second.
7. If half wave field is required, motor field windings are to be connected between F1 and L1.
8. Factory set to accept 0 - 5 Vdc; cut J2 for 0 - 10 Vdc operation.

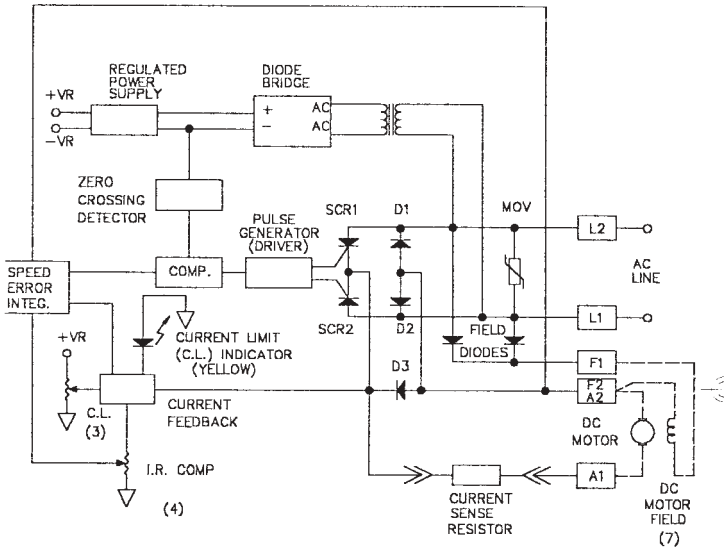

## UNIT FUNCTIONS CONTINUED

To program the S1000 for either a NO or NC type INHIBIT conditions, the unit's logic should be set with Jumper J1. Jumper J1 is a 10K ohm; 1/4 watt resistor which is located between the inhibit and SP2 terminals on the S1000 circuit board. See Component Location page 21 for further information. The two methods for using the INHIBIT are described further on the following page.

## OPEN Method

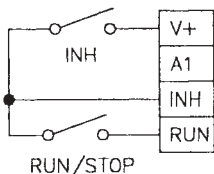

Jumper J1: IN Place\*

INH-Activated during OPEN condition, must be CLOSED for unit to RUN

RUN-Close to RUN; Open to Stop

## CLOSED Method

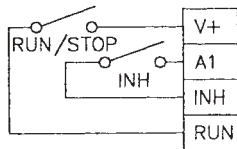

Jumper 1: Cut

INH-Activated during a CLOSED condition, must OPEN for unit to RUN

RUN-Close to RUN; Open to STOP

\*Factor installed

Note: In the CLOSED method, the RUN (green) LED will remain lit if a RUN command is present, even if unit is INHIBITED.

If the INHIBIT function is not desired, CUT jumper J1 and wire the RUN/STOP circuit as shown in the CLOSED method. No wiring to A1 or INHIBIT will be required.

**CAUTION:** INHIBIT is a logic convenience and should not be used as an Emergency Stop. INHIBIT cannot override a catastrophic drive failure. A system Emergency Stop function, necessary to protect personnel or equipment, will always remove AC power from the S1000.



## WIRING

1. Refer to Ratings Chart (pg 8) for incoming line current and fuse rating. It is the responsibility of the user or person installing the controller to provide branch circuit protection according to NEC and local codes. On controllers using 120 VAC input, be sure the incoming hot lead is connected to L1 and common is connected to L2.
2. A full wave field is provided for use with shunt wound motors when required. Field voltage on 120 VAC line is 100 VDC. If the motor requires a 50VDC (half wave) field voltage, connect field windings from F1 to L1. Field voltage on 240 VAC line is 200 VDC. If the motor requires a 100 VDC field, follow the procedure outline above.
3. Refer to Ratings Chart (pg 8) for appropriate Current Sense Resistor size that is needed, depending upon the horsepower of motor to be used.
4. A speed potentiometer is available for use with each controller and is rated at 5k ohm, 1W.
5. An isolated process signal may be used instead of a potentiometer by connecting signal leads between terminals SP2 and A1, with positive to SP2. The S1000 is factory set to follow a 0-5VDC signal. By removing Jumper J2, a 0-10VDC signal may be used. Jumper J2 is a 22ohm: 1/4 watt resistor located next to SP2 and SP3 terminals on the S1000 circuit board. BE SURE THAT SIGNAL IS ISOLATED FROM GROUND, OR CONTROL WILL BE DAMAGED.

6. **WARNING: ALL TERMINALS OF THE UNIT ARE AT LINE POTENTIAL AND CAN BE EXTREMELY HAZARDOUS. POWER MUST BE REMOVED FROM UNIT BEFORE ANY WIRES ARE CONNECTED. FAILURE TO COMPLY MAY RESULT IN PERSONAL INJURY, EQUIPMENT FAILURE, OR BOTH.**
7. Switching devices to be used for RUN/STOP or INHIBIT must meet the following specifications: 15VDC, 15 mA, with leakage current less than 1 mA.

## VERIFICATION TEST

Use caution during these procedures because the line voltage will be present on the power and motor terminals, as well as on the printed circuit board, when power is on. See the Component Location (pg 8) to identify parts referenced during these instructions.

**CAUTION:** Do not earth ground the switch and Speed Pot terminals.

**NOTE:** If, at any stage of this procedure, the control does not act as indicated, refer to the Troubleshooting Guide page .

1. With AC power off, recheck to be sure that all power and control connections are properly secured and connected according to the WIRING section.

2. Set the Speed Pot to Minimum Speed (CCW), and place the external RUN/STOP switch in the STOP position
3. Apply power to the control. Place the RUN/STOP switch in the RUN position. The RUN (green) LED should glow, but the motor should not turn. If LED does not come on, verify that INHIBIT is not activated.
4. Slowly rotate Speed Pot in a clockwise direction. Motor should begin turning. Continue to rotate Speed Pot until desired motor speed is achieved.

# COMPONENT LOCATION

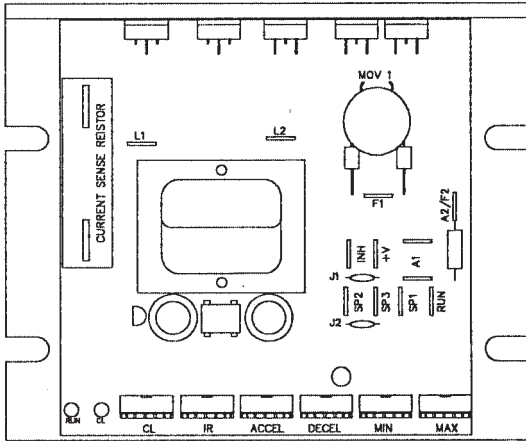

## SET-UP PROCEDURES

The Vari Speed S1000 has been set up at the factory to satisfy most application needs. You may, however, wish to tailor your control specifically to your application requirements. If so, follow these instructions for proper set-up.

### FACTORY SETTINGS

MIN SPEED	Zero volts
MAX SPEED	90VDC Output for 120 VAC line 180VDC Output for 240 VAC line
Current Limit (CL)	100% of Control Rating
IR Compensation	Set for no compensation
ACCEL	Minimum
DECEL	Minimum

NOTE: Before making any adjustments, start control and run motor fully loaded for at least 30 minutes so motor temperature will stabilize. (Motor speed will increase as temperature increases).

## CURRENT (TORQUE) LIMIT ADJUST (CL) (Clockwise Increases Current)

There are two methods for adjusting CL.

### METHOD 1:

1. Start the machine and run at desired speed, then apply maximum load to the motor and turn CL trimpot fully clockwise.
2. Turn CL trimpot counterclockwise until the CL . (yellow) LED lights and the machine starts to slow down.
3. Turn the CL trimpot clockwise until the CL (yellow) LED just turns off.

### METHOD 2:

1. Turn off AC power.
2. Lock up the motor shaft, taking care not to cause damage.
3. Connect a DC ammeter in series with the motor armature.
4. Turn CL trimpot fully counterclockwise.
5. Turn external speed pot fully counterclockwise.
6. Turn on AC power and start control (CL (yellow) LED should be on).
7. Turn speed pot clockwise to about 1/3 speed setting.
8. Adjust CL trimpot clockwise for desired motor current. (Do not set for current greater than either the motor or control nameplate rating).
9. Turn off AC power, disconnect ammeter, and unlock motor shaft. CL may be adjusted from 0-150% of control rating.

## IR COMPENSATION ADJUSTMENT (IR) (Clockwise Increases Compensation)

This adjustment is provided to overcome the motor's natural tendency to slow down with increasing load. If improved load/speed performance is required, this adjustment may be used.

NOTE: In order to optimize performance with this adjustment, some means of determining motor shaft speed is required. (i.e. hand-held tachometer).

1. Set motor speed to 1/2 of base speed rating.
2. Load motor to 100% of nameplate rating; motor speed will decrease.
3. Turn IR clockwise until motor speed returns to original unloaded RPM.
4. Turn off load and notice if RPM increases beyond original setting. If so, adjust trimpot while changing from no load to full load to give minimum RPM change for each.

NOTE: Setting IR adjust too high can create motor instability. Turn IR CCW until motor speed stability is achieved.

## MINIMUM SPEED ADJUSTMENT (MIN) (Clockwise Increases Minimum Speed)

1. Turn external Speed Pot fully counterclockwise (CCW).
2. Turn MAX Speed Trimpot fully CCW.
3. Produce a RUN command so that the RUN LED (green) is on and adjust the MIN SPEED trimpot until desired minimum speed is set. If desired minimum speed is zero, adjust trimpot clockwise until motor starts turning, then turn the trimpot counterclockwise until the motor barely stops turning. (This will give the best motor speed linearity).

MIN SPEED may be adjusted from 0 to 50% of motor's rated base speed.

## MAXIMUM SPEED ADJUSTMENT (MAX) (Clockwise Increases Maximum Speed)

1. Produce a RUN command so that the motor is operating at full load, and the external Speed Pot is turned all the way to maximum, adjust the MAX SPEED trimpot until desired speed is set. (Note: Extended motor speed can be achieved with the trimpot).

MAX SPEED may be adjusted from 50% to 110% of base speed. Caution should be taken not to exceed maximum motor name - plate speed rating.



## ACCELERATION (ACCEL)/ DECELERATION (DECEL) ADJUSTMENTS

Set these two trimpots for desired times. Both ACCEL and DECEL trim pots adjust from a linear .5 to 15 seconds. Acceleration rate may be extended with CL if reflected inertia is high. DECEL may be longer if reflected inertia is high.

## TWO-SPEED APPLICATION

By using single-pole, double throw (SPDT) relay or switch, preset two-speed operation is possible.

1. Replace external speed pot with SPDT contacts as shown below.
2. With SPDT contacts closed between terminals SP2 and SP3, adjust the MIN SPEED trimpot to desired low speed.
3. With SPDT contacts closed between terminals SP1 and SP2, adjust the MAX SPEED trimpot to desired high speed.

NOTE: SPDT must be capable of reliability switching 5VDC @ 1 mA. (i.e.-gold contacts).

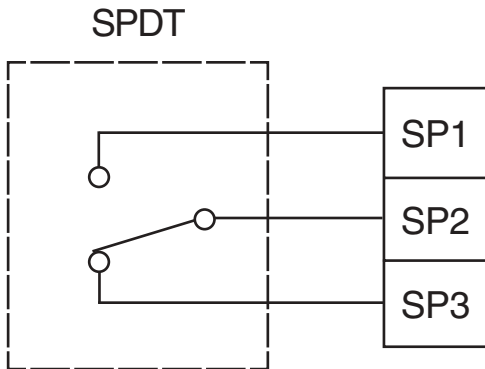

## TROUBLESHOOTING GUIDE

### MOTOR WILL NOT RUN:

1. Make sure power is applied to unit. If not, make sure disconnect fuses or circuit breaker in line are okay.
2. Make sure RUN switch is on (RUN (green) LED should be lit).
3. Make sure INHIBIT connection is correct. (see page ).
4. Be sure Speed Pot is not set to zero.
5. Current Sense Resistor is not installed properly.
6. Unit is in Current (torque) Limit. Check CL (yellow) LED (if lit, this indicates that CL pot is set too low, or motor is overloaded).
7. With power removed from unit and motor leads disconnected, check for worn or improperly seated brushes.
8. Defective control.

### FUSE BLOWING:

1. Improper wiring - check wiring for misrouting, shorts, and shorts to ground.
2. Motor brushes worn or improperly seated.
3. Motor load is too heavy. Check for machine “jamup”, or excessive load.
4. Defective control.

#### NO SPEED CONTROL:

1. Speed pot or wiring defective.
2. Control not set up properly (See Set-Up Procedures, pg 22)
3. Defective control.

#### MOTOR WILL NOT RUN AT 1725 RPM:

1. Improper setting MAX Speed trimpot (range trimpot with isolated units). Rotate trimpot clockwise to increase speed.
2. Unit is in Current (torque) Limit, Check CL (yellow) LED (if lit, this indicates that CL pot is set too low, or motor is overloaded).
3. Low line voltage.

If you require assistance, please contact your local distributor, or the factory by calling toll free 888-363-1313.

## PLUG-ON TERMINAL OPTION

The Plug-On Terminal board provides for easy wiring for standard 14-20 AWG wire.

1. Refer to drawing below for proper terminal wiring.  
NOTE: Wiring to Terminal Board before installation to Vari Speed S1000 may simplify procedure.
2. Carefully plug-on the Terminal Board to the Vari Speed S1000 making sure that all connectors are properly aligned.

Terminal board Part Numbers:

- 176B1113, 120 VAC
- 176B1114, 240 VAC

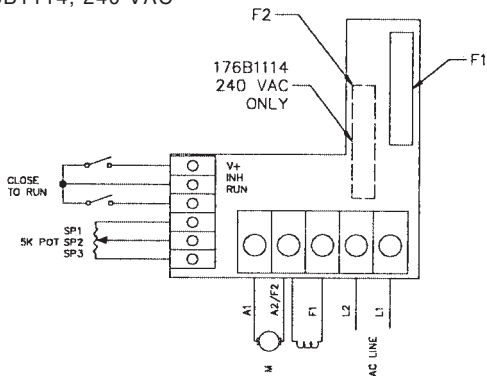

## AVAILABLE OPTIONS FOR VARI SPEED S1000

**Plug-on Terminal Board:** 176B1113, 120 VAC or  
176B1114, 240 VAC

- Allows termination of stripped 14 to 20 AWG (lugless) wires.

**Heatsink:** 176B1122

- For use in higher horsepower applications.

**Potentiometer Kit:** 176B1121

- Includes a 5k ohm, 1 W pot, and mounting hardware.
- Knob and dial plate are also available separately.

**Current Sensor Resistor:**

- Plug-on design allows for easy field modification.
- Refer to Ratings Chart (pg 8) for correct part number.